



**Coimisiún na Scrúduithe Stáit**  
**State Examinations Commission**

**Leaving Certificate 2016**

**Marking Scheme**

**Construction Studies**

**Higher Level**

### **Note to teachers and students on the use of published marking schemes**

Marking schemes published by the State Examinations Commission are not intended to be standalone documents. They are an essential resource for examiners who receive training in the correct interpretation and application of the scheme. This training involves, among other things, marking samples of student work and discussing the marks awarded, so as to clarify the correct application of the scheme. The work of examiners is subsequently monitored by Advising Examiners to ensure consistent and accurate application of the marking scheme. This process is overseen by the Chief Examiner, usually assisted by a Chief Advising Examiner. The Chief Examiner is the final authority regarding whether or not the marking scheme has been correctly applied to any piece of candidate work.

Marking schemes are working documents. While a draft marking scheme is prepared in advance of the examination, the scheme is not finalised until examiners have applied it to candidates' work and the feedback from all examiners has been collated and considered in light of the full range of responses of candidates, the overall level of difficulty of the examination and the need to maintain consistency in standards from year to year. This published document contains the finalised scheme, as it was applied to all candidates' work.

In the case of marking schemes that include model solutions or answers, it should be noted that these are not intended to be exhaustive. Variations and alternatives may also be acceptable. Examiners must consider all answers on their merits, and will have consulted with their Advising Examiners when in doubt.

### **Future Marking Schemes**

Assumptions about future marking schemes on the basis of past schemes should be avoided. While the underlying assessment principles remain the same, the details of the marking of a particular type of question may change in the context of the contribution of that question to the overall examination in a given year. The Chief Examiner in any given year has the responsibility to determine how best to ensure the fair and accurate assessment of candidates' work and to ensure consistency in the standard of the assessment from year to year. Accordingly, aspects of the structure, detail and application of the marking scheme for a particular examination are subject to change from one year to the next without notice.



**Coimisiún na Scrúduithe Stáit**  
*State Examinations Commission*

*Scrúdú Ardteistiméireachta 2016*

# *Staidéar Foirgníochta*

## *Teoiric – Ardleibhéal*

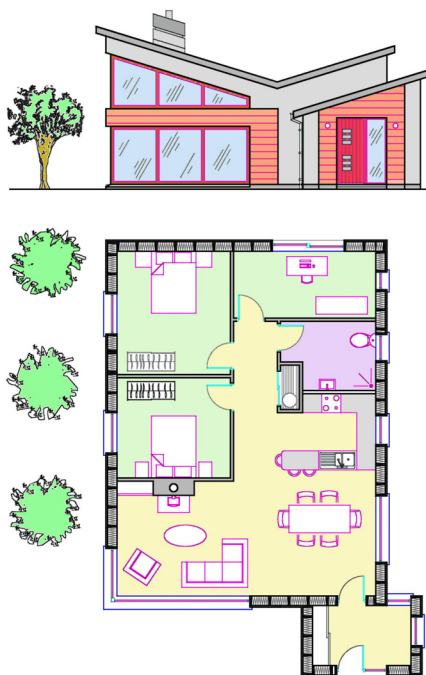

# *Construction Studies*

## *Theory – Higher Level*

**Note:** Notes and graphics are for illustration and are not definitive nor exhaustive, other relevant notes and graphics are acceptable as responses and will be credited accordingly.

**Ceist 1. Typical details for flat roof, roof abutment, window head and wall details – such as:**

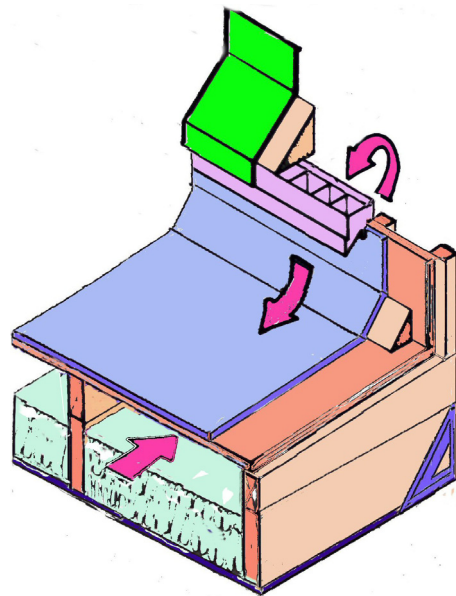
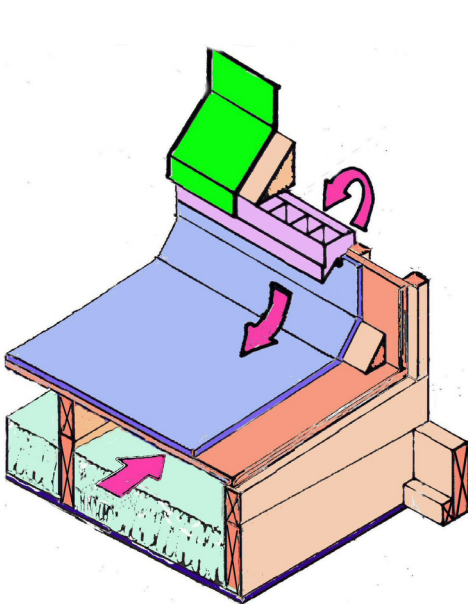
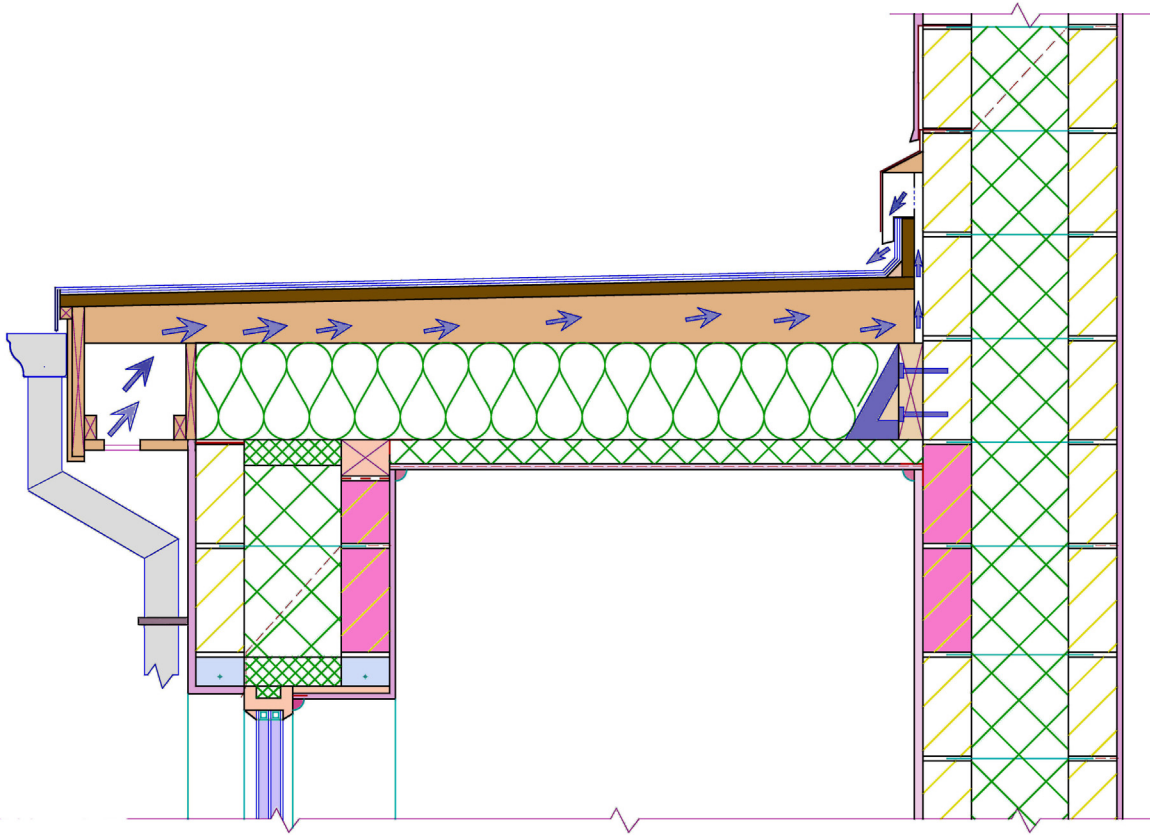

(i) Typical best practice details of flat roof to front porch – through and through ventilation

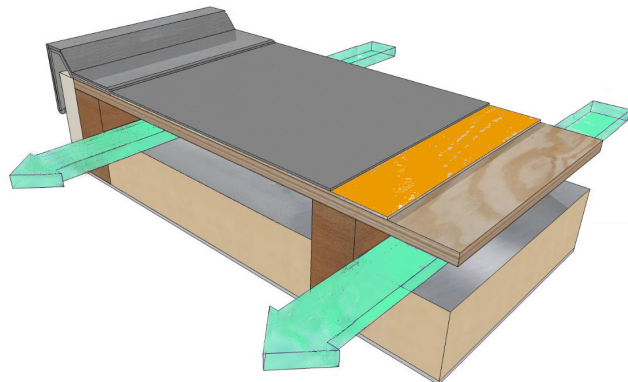
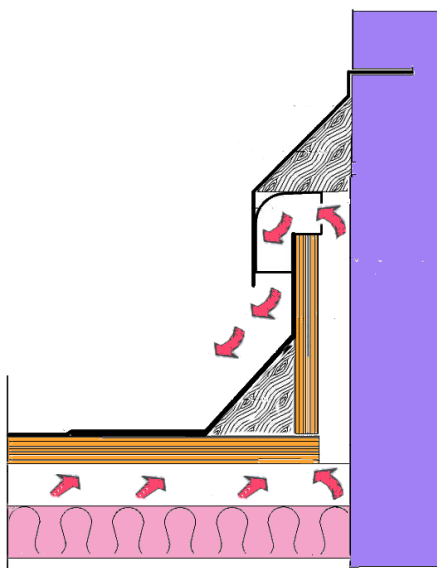
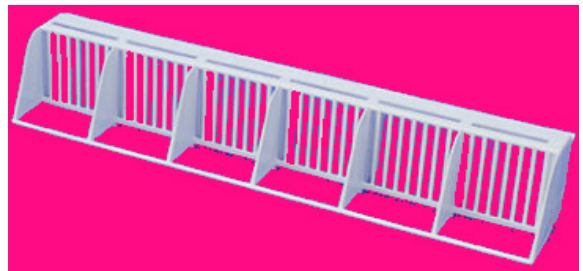
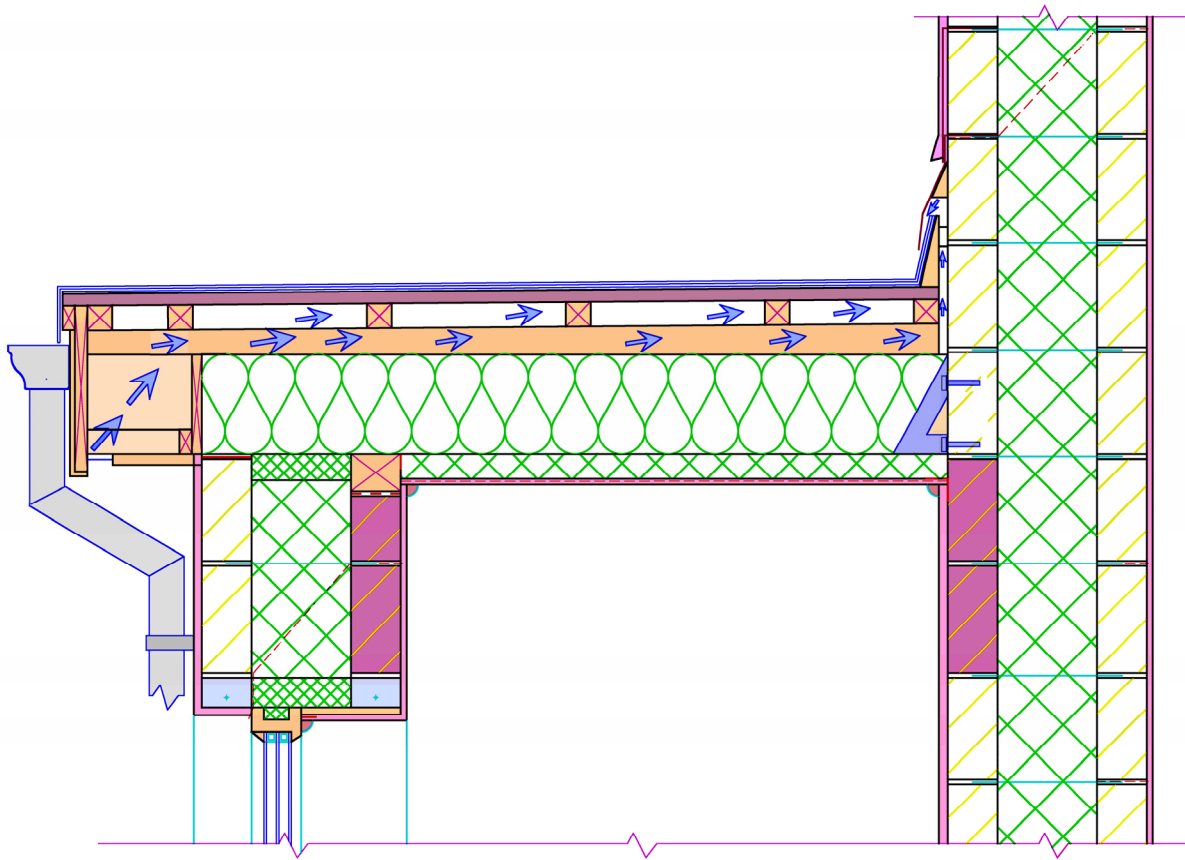

**Wall – typical details**

- external plaster finish, scud coat, undercoat, floated sand /cement finish coat
- 100 mm concrete block outer leaf
- 200 mm full fill insulated cavity
- basalt coated low conductivity wall ties
- 100 mm concrete block inner leaf
- fireproof cavity closer
- 15 mm internal skim coat or cement /sand render– 2 coats or lime plaster internal render.

**Typical details - roof**

- galvanised steel wall brackets secured with resin anchored bolts to wall *or*
- 200 × 50 mm wallplate secured to wall with resin anchored bolts
- galvanised steel wall brackets secured to wallplate
- 100 × 70 mm wall plate secured to inner leaf
- 200 × 50 mm roof joists @ 400 mm centres
- furring piece to slope of 1: 20 to each roof joist
- bridging 200 × 50 mm to roof joists
- counter battens 50 × 50 mm for ventilation to roof structure
- marine ply / WBP plywood decking, 18 mm secured to counter battens
- 3 layer bituminous felt fixed to plywood decking
- proprietary vents fitted at wall abutment for ventilation
- flashings and counter flashings at abutment to wall, lead, zinc, pressed aluminium, copper etc
- insulation 200 mm min between roof joists
- vapour control layer on warm side of insulation, taped at wall junctions
- insulated plasterboard fitted to underside of roof joists
- skim finish to ceilings and walls
- scrim/tape at wall and ceiling junction to ensure airtightness
- junction at wall taped for air tightness
- fascia and soffit with proprietary vents on soffit for roof ventilation

**Window Details**

- reinforced concrete lintels
- fireproof cavity closer
- stepped flashing over window
- window fixed at external leaf
- plywood cavity box to close cavity
- gypsum plasterboard to cover plywood box and render fireproof
- thermally broken window frame
- low- e triple glazing with low conductivity spacers between panes
- argon or krypton gas between panes
- window frames taped to blockwork /plasterboard for airtightness.

**Ceist 2 (a) Safety training:**

- safety training is essential in order to develop awareness amongst workers of possible hazards and risks on site
- safe pass certification compulsory for site personnel
- effective safety training can help workers prevent serious injury to themselves or to other workers
- safety training is required whenever workers undertake new practices which involve a change in the nature or level of risk
- additional training is required for the use of specialist equipment
- training aims to instil a culture of awareness and positive action to ensure a safe working environment on a construction site.

### Initial safety training

- it should never be taken for granted that new workers will have the knowledge and experience to anticipate dangerous situations
- the aim of initial safety training is to provide all new workers with the skills and knowledge which more experienced workers may have built up over time
- the first hours and days in new surroundings or dealing with new practices often prove the most dangerous
- initial safety training should take place before starting work for the first time or before undertaking new procedures or practices.



### Ongoing safety training

- as workers gain in experience, they often tend to become less aware of hazards and risks
- ongoing focussed training is needed to guard against reduced awareness over time
- safety representative appointed
- accidents are minimised or eliminated through ongoing safety planning and constant risk assessment which are then communicated to workers through training.

### Collective responsibility

- collective responsibility is a culture where everyone on site looks out for the safety of others
- the culture of the group becomes one of safety consciousness
- awareness of issues of safety becomes a shared experience
- when all workers are vigilant and safety conscious, good safety practices are followed
- when workers as a group actively consider elimination of hazards and minimisation of risks, the culture of the group changes
- opportunities should be provided for all workers to consider the hazards and risks associated with their work
- as workers become aware of new or increased levels of risk they should have been made aware of the procedures to follow to raise the awareness of their co-workers of the risk
- the adoption of best safety practices and procedures becomes the norm amongst workers
- safety is too important an issue not to be the responsibility of everyone
- a firm commitment from management to monitor and improve health and safety on site is required but does not excuse others of responsibility
- while management has a particular responsibility, best practice dictates that even the most junior worker shares the responsibility with everyone else
- responsibility flows through the safety officer and safety committee and is kept in the group consciousness by regular review and update of the health and safety statement
- safety awareness and reporting of any potential hazards provides a channel for involvement of all workers
- through shared responsibility, safety consciousness becomes internalised
- mandatory reporting of accidents and near accidents in order to better inform policy making is essential
- enforcement of rules by the health and safety authority further reinforces compliance
- fines and penalties are an incentive for companies to follow best practice.

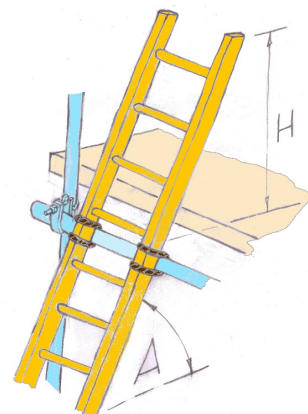

**(b) Appropriate use of a ladder****Level of risk**

- the use of a ladder on a construction site is always hazardous unless correct procedures are taken to ensure maximum safety
- a risk still remains after all possible procedures are taken to eliminate or minimise hazards
- if the level of risk remains unacceptably high other solutions should be considered such as the use of a lift, mechanical hoist
- careful safety planning aims to eliminate the hazard or where this is not possible, to minimise the remaining risk
- risks involved include:
  - ladder becomes dislodged due to poor fixing at the top or bottom
  - falls due to poor arrangements where the ladder reaches the platform
  - poor positioning of safety handrail within reach at the top of the ladder
  - the angle of the ladder is too steep or too shallow
  - over-reaching of the worker
  - fatigue owing to long time standing on narrow ladder rung
- the level of risk is increased either by increased likelihood of failure
- the potential consequences of failure become more severe as the working height increases and particular attention has to be paid to the minimisation of risk in these cases
- even where the working height is low, due care has to be taken - mindful that even a short fall can lead to serious injury.

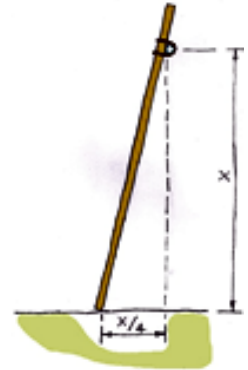
**Duration of task**

- the level of risk is increased when the ladder is to be used over an extended period of time
- working at a high-level may increase the risk levels - in such cases the use of a lift or hoist should be considered
- where the duration of the task is not long, due consideration should still be paid to the issue of safety
- accidents can happen if proper safety practices are not followed even when the duration of the task is short
- where a ladder is in place for long periods, regular checking of the risk control measures should be planned
- checking of the fixings of the ladder at top and bottom should be scheduled as part of regular safety audits of the site
- use a ladder only where the risk is low, the duration of task is short, the work is light and you can maintain three points of contact
- to avoid working for a long period from a ladder, use a mechanical hoist, or a scaffold

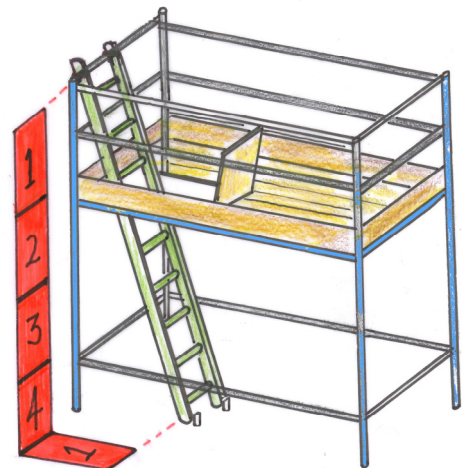
**(c) Best practice safety guidelines**

- the ladder must be securely held/tied at both ends, being mindful that there is very little frictional resistance between the ladder and the scaffold
- where there is uneven ground, appropriate measures should be taken to provide a level grounding for the foot of the ladder
- the ladder should extend at least 1.0 metres above the platform surface
- the horizontal distance of the foot of the ladder from the platform should be  $\frac{1}{4}$  the height of the platform - a slope of  $74^\circ$  is recommended
- the ladder should be carefully positioned to allow ease of access to the platform such that users are protected by safety rails, toe boards and safety gates
- where the height of the scaffold platform is more than one storey, use should be made of multiple ladder runs
- the ladder must be structurally sound and designed to carry the required loads.

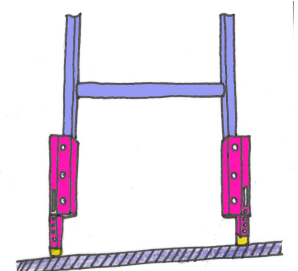



**Ceist 3 (a) (i) – Redesign for natural light – external envelope and revised internal layout****Internal Layout**

- kitchen and dining area moved to front /south of house to avail of natural sunlight
- infrequently used rooms positioned at the northern end of the dwelling
- bathroom/bedroom moved from front to north/rear of house
- open plan to allow penetration of natural light
- load bearing wall A-A should remain in place
- additional openings may be created if completed to engineer's specification.

**External Envelope**

- glazing increased at southern, eastern and western elevations, minimal on northern elevation
- install high performance windows - low-e double and triple glazing
- incorporate sky tunnel into roof for natural light to north facing rooms
- floor to ceiling glazing increases natural light
- follow Local Authority Planning guidelines with reference to remodelling the front elevation of the dwelling
- roof lights will increase natural light.

**Ceist 3 (b)****Internal layout**

- south facing facades should have large windows and openings to maximise natural light - it is advantageous to have living areas to the south
- keeping furniture away from windows will enhance the flow of both space and of light
- painting window frames a light colour internally will increase the amount of reflected light- keep window dressings light in both colour
- adding a roof light to an internal hallway can make it a light filled space and avoid having to artificially light it during the day
- natural light enhances internal space and gives a sense of comfort and well-being
- fitting a glass door from a bright living room to a dark hallway can bring light into the hallway and highlight the entrance to the main room
- balance the flow of light in the house as a whole, where space and other considerations allow, by opening up between the front and rear rooms - this will allow, for example, a north facing rear room benefit from the sun
- use of appropriately placed mirrors to maximise reflective light
- selective use of colour – dark colours absorb light and make a room appear dark and smaller.

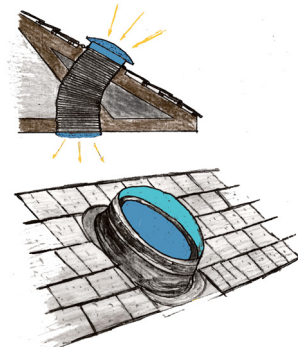

### External envelope

- south facing principal elevation to maximise natural light
- fewer and smaller windows on the north elevation reduces heat loss
- extended roof lights over front door for maximum sunlight to penetrate to the hall area
- tall / full height large south facing windows allow for maximum natural light to the living areas
- east facing window allows morning sunlight to the sitting room
- increase glazing on southern and western elevations of dwelling
- rooflights /sky tunnels/light pipes inserted/integrated into roof – sized proportionate to roof and placed aesthetically
- occupants can engage in activities to take advantage of natural light
- olfactory comfort - fresh air, fresh smells, - indoor plants for air cleanliness, plants for pleasant indoor atmosphere

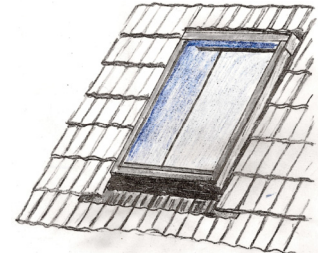

### Any other relevant points

**Ceist 4 (a)** - Why site A may be considered suitable for a new house.

Discussion points– *such as*

- the site is sufficiently large to accommodate a house in the countryside
- the proportions of the site are suitable
- there is sufficient space to accommodate waste-water treatment and a percolation area
- the site has public access from the adjoining roads
- there is the possibility of having a southerly aspect to allow for sustainable house design
- the site is close to existing houses and settlements so that services such as water, electricity, phone and broadband are likely to be readily available and cost effective
- roadways are mainly straight and allow sufficient sightlines from entrance to ensure safe access to roadways from site – vehicle driver can see oncoming traffic.

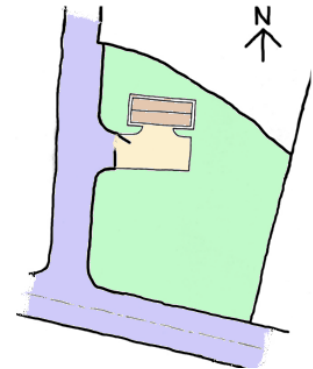

### (b) Location and orientation on site A entrance and access road.

**The house is positioned so that:**

- front elevation is oriented to south to be sustainable and obtain maximum solar gain
- it is close to the public road and services
- the length of driveway is kept short for economy
- house is not overlooked
- it is not visually obtrusive in the surroundings
- there is sufficient area in the remainder of the site to provide for the unobtrusive provision of waste-water treatment and percolation
- design and scale of house to reflect the type and form of surrounding vernacular buildings

**The entrance gateway and access road:**

- provide clear sightlines when entering and exiting
- entry is from a quiet side road to minimise traffic risks
- are sited sufficient distance from the junction with the main road so as to minimise risk from/to fast-moving traffic
- are sited sufficient distance from the bend and entrance to the neighbouring house
- provide perpendicular access for vehicles to the public road improving driver vision
- allow sufficient space for off-road stopping or parking when the gates are being opened
- provide a frontal view of the house as it is approached.

**Other site designs and roadway layouts acceptable and supported by cogent justification**

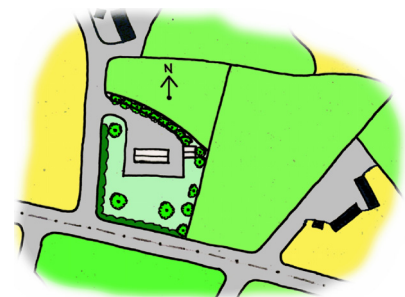

**(c) Advantages of one-off houses in the Irish rural landscape – such as:**

- they allow local people to live amongst their neighbours and extended family
- they provide a quality of life enjoyed by rural dwellers
- they allow people to live in healthy surroundings with clean air
- many people value the quietness and solitude of living in this type of house
- they can create a network of rural dwellers who can develop community spirit
- having extra rural dwellers aids the rural economy
- rural dwellers tend the countryside - farmers, ecologists, nature lovers, gardeners etc.
- rural dwellings give a welcoming feel to the countryside - an inhabited landscape
- provide a different paradigm to urban dwelling – it is acceptable to live in the countryside
- having more rural dwellers maintains the level of services available.

**Disadvantages of one-off houses in the Irish rural landscape:**

- it is unsustainable
- construction costs are higher – long distances, increased transport costs
- rural dwellings is more expensive to maintain
- services such as electricity, water, gas, broadband etc. may not be easily available
- transport costs to access all services are increased – towns, schools, churches, leisure, healthcare
- regular, reliable public transport may be unavailable
- children spend more time travelling to school and may have to use a school bus or be driven
- school-going children may find involvement in extra-curricular activities difficult
- it may destroy the visual amenity for other citizens, both local and passing
- it may become increasingly more unsustainable as fossil fuels become scarce and more expensive
- as the householders age they may find it increasingly difficult to access required supports and to remain active as they become more confined due to the remote location of the house.

***any other relevant points***

**Ceist 5 (a): U-value of wall A**

Material Element	Conductivity k	Resistivity r	Thickness T(m)	Resistance R
Ext. Render		2.170	0.019	0.04123
Concrete Block(ext)	1.320		0.100	0.07575
OSB Racking Board	0.130		0.018	0.13846
Mineral Wool insulation	0.040		0.120	3.00000
Plasterboard	0.160		0.0125	0.078125
Cavity				0.17000
Ext. Surface				0.04800
Int. Surface				0.10400
			Total R	$R^t = 3.655565$
		<b>Wall A</b>	<b>U-value 1/R</b>	<b>0.27356</b>
		<b>Wall B</b>	<b>Given U-value</b>	<b>0.15</b>

**5(b) Cost of heat lost annually through the wall**

**Formulae:**  $R=T/k$        $R=T \times r$        $U= 1/R^t$

U-value:  $U = 1 / 3.655565 = 0.273555 \text{ W/m}^2 \text{ }^\circ\text{C}$ .

**Wall A**

- Heat loss formula:  $= U \text{-Value} \times \text{area} \times \text{temp. diff}$   
 $0.273555 \times 150 \times 12 = 492.39994 \text{ Watts. (Joules / sec)}$
- Heating period p/a:  
 $60 \times 60 \times 8 \times 7 \times 38 = 7,660, 800, \text{ seconds (2,128 hours)}$
- Kilo joules p/a:  

$$\frac{7,660, 800 \times 492.39994}{1000} = 3772168.08 \text{ kJ}$$
- Litres p/a: (Note: Calorific value of 1 litre oil = 37350 kj)  

$$\frac{3772168.08 \text{ kJ}}{37350} = 1009.95 \text{ litres}$$

Cost p/a: (Note: 1 litre of oil costs 96 cent.)

$$1009.99 \times 0.96 = \text{€}96.96$$

**Cost of heat loss annually through wall A = €96.96**

**Alternative method:**

$$\text{Formula: } \frac{U\text{-value} \times \text{Area} \times \text{Temp Diff.} \times \text{Time (secs)} \times \text{Cost (Euros)}}{\text{Calorific value} \times 1000}$$

$$\begin{aligned} (1) &= \frac{0.27355 \times 150 \times 12 \times 7,660,000 \times 0.96}{37,350 \times 1000} \\ &= \frac{3,620,839,104}{37,350,000} \\ &= \mathbf{€96.94} \end{aligned}$$

**Q.5 (c) Find thickness of expanded polystyrene insulation required to give U-value of 0.15 W/m<sup>2</sup> °C.**

**Determine the Resistance for a U-value of 0.27356 W/m<sup>2</sup> K**

Use formula  $U = 1/Rt$ . & solve for R.

$$R = 1 / U\text{-value} \quad R = 1 / 0.2725 = 3.6555 \text{ m}^2 \text{ K} / \text{W}$$

$$\text{Resistance for required U-value of } 0.15 = 1 / 0.15 = 6.6666 \text{ m}^2 \text{ K} / \text{W}$$

$$\text{Difference in Resistance} = 6.6666 - 3.6555 = 3.0111 \text{ m}^2 \text{ K} / \text{W}$$

Use the formula  $R = T/k$  & solve for T.

$$3.0111 = T / 0.037$$

$$T = 3.0111 \times 0.037 = 0.1114107 \text{ metres}$$

$$\text{Thickness of required Expanded Polystyrene insulation} = 111.4107 \text{ mm}$$

111/112 mm acceptable.

**Alternative calculation methods acceptable.**

**Ceist 6**

**(a) Three features of the design that contribute to the house having low environmental impact – such as:**

- the cedar cladding finish on the exterior is carbon neutral and reduces the embodied energy of the house, giving a low-carbon construction
- the tree planting indicated reduces the visual impact of the building and help with carbon sequestration
- the planting of trees indicated in the drawing softens the contrast between the natural setting and the geometric nature of the architecture
- trees to provide shade, food and shelter for birds and humans and aid biodiversity
- the cedar cladding needs no preservatives, naturally durable
- the use of timber-frame construction leads to renewable materials providing storage of CO<sub>2</sub> sequestered from the atmosphere
- the large areas of glazing and the double height glazing, which are presumed to be south-facing, lead to solar gains which help to reduce the use of non-renewable fossil fuels for space heating
- the smaller windows to the north-facing elevations reduce heat loss and help conserve energy

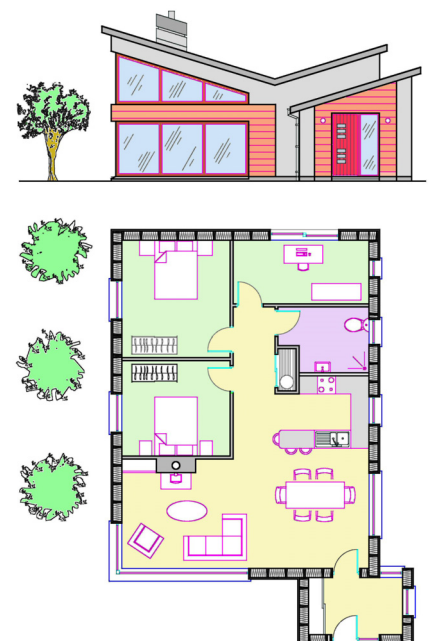

- the stove and associated flue are placed against an inner wall of high thermal mass, increasing the storage of heat within the fabric of the house
- wood burning stoves are carbon neutral and stoves are up to 70% efficient
- open-plan, naturally lighted layout
- short circulation areas and corridors
- hot press adjacent to bathroom and kitchen, short pipe runs and reduced hot water run off needed
- the entrance lobby/storm porch greatly reduces the loss of heated air when the door is used
- the compactness of the design reduces the volume of the air to be heated
- the area and orientation of the fenestration support the use of passive solar gain to complement space heating
- the compact footprint of the building reduces the area of the exterior envelope of the building, helping to conserve materials and heat

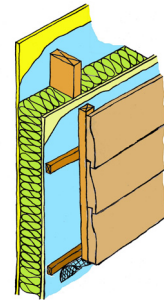

**(b) One means of generating on-site renewable energy for the dwelling house to meet the Nearly Zero Energy Building (NZEB) requirements.**

A Nearly Zero Energy Building is a “building that has a very high energy performance... . The nearly zero or very low amount of energy required should to a very significant extent be covered by energy from renewable sources, including renewable energy produced on-site or nearby.” NZEB standards to be introduced from 2019 for all publicly-owned buildings and from 2021 for all buildings.

*Wind charger/micro generator for electricity generation*

- individual turbines vary in size and power output, ranging from a few hundred watts as used on caravans through 5 or 6 kW turbines, from 1.5 m to 2.0 m in diameter suitable for a single dwelling, to 2-3 megawatts for community-owned turbines or wind farms supplying electricity to the national grid
- wind speed is critical for electricity generation
- height of turbine is also critical: a turbine should be a minimum of 10.0 m above the roof or any other obstruction within 100.0 m - such as buildings or trees, to reduce turbulence, which reduces efficiency and causes undue wear
- a micro turbine between 1.5 m and 2.0 m in diameter will provide about 10% of the average power use of a house - 4700 kW hr/year
- most small wind turbines generate direct current (DC) electricity
- off-grid systems require battery storage and an inverter to convert DC electricity to AC alternating current, as used for mains electricity
- no battery storage is required if connected to the grid
- a controller is also required to ensure the batteries are not over- or under-charged.
- solar panels can also be used for water heating

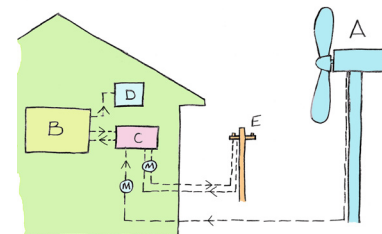

*evacuated tubes*

- evacuated tubes can provide up to 60% of hot water requirements - less electricity used
- the installation of evacuated tubes reduces demand for mains electricity for domestic water heating

*photovoltaic (PV) panels to generate electricity*

- solar energy can also be turned into electricity in a photovoltaic (PV) panel, which converts solar energy into electrical energy using silicon cells
- small photovoltaic panels are often used to power calculators, which require very little power
- photovoltaic panels are used for houses that cannot be supplied from the grid
- photovoltaic panels are becoming more economic for domestic electricity generation
- photovoltaic panels reduce the use of mains electricity replacing some of the mains power with electricity from renewable sources
- average annual consumption of electricity per household is about 3.0 to 4.7 kW – an area of 21.0 m<sup>2</sup> of photovoltaic panels produces about 3.12 kW of electricity
- lithium-ion batteries are being developed to store electricity generated by photovoltaic panels – e.g. Tesla Powerwall home batteries which store enough energy to allow you go off-grid

*other means*

- air to water exchanger for space heating system
- water to water exchanger for space heating
- earth to water exchanger for space heating
- aim of nZEB is to provide all energy requirements on-site and to go off-grid.

**(c) Two advantages of generating renewable energy on-site**

- it can be a sustainable alternative to using mains electricity generated mostly from fossil fuels
- the natural resources harnessed to generate the energy are freely available
- payment of carbon taxes is reduced or avoided
- energy losses encountered in transmission of mains electricity are avoided
- the cost of transporting the replaced fossil fuels to the house - oil, coal, wood etc, are avoided
- the provision and maintenance of an appropriate road system for the transport of reduced amounts of fossil fuels becomes easier
- roof slope is often ideal for photovoltaic cells – 30° to 45° slope with southern orientation
- in rural areas, site may be suitable for the erection of wind turbine to generate on-site electricity
- the householder shares in the steps taken to address climate change and the allied satisfaction
- the household becomes less dependent on mains electricity, with the increasing prospect of the use of battery storage and being able to go off-grid
- advances in the development of lithium-ion batteries for the domestic electrical storage - note the development of Tesla batteries for electrical energy storage
- as a rule of thumb allow 1.0 -1.5m<sup>2</sup> solar collector area per person for water heating needs
- all pipework to be insulated to avoid heat losses and UV stable if exposed
- performance of collector may be affected by overheating
- ensure air flow between roof surface and back of the collector
- optimum tilt angle for solar collector is 45°.

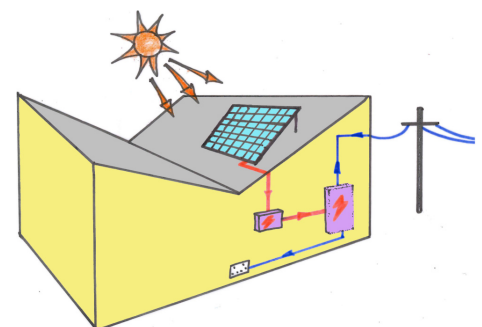
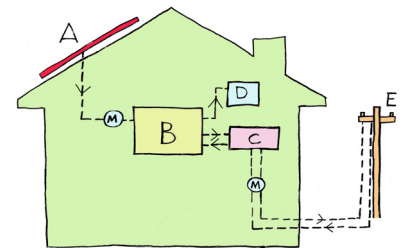
***Any other relevant points***

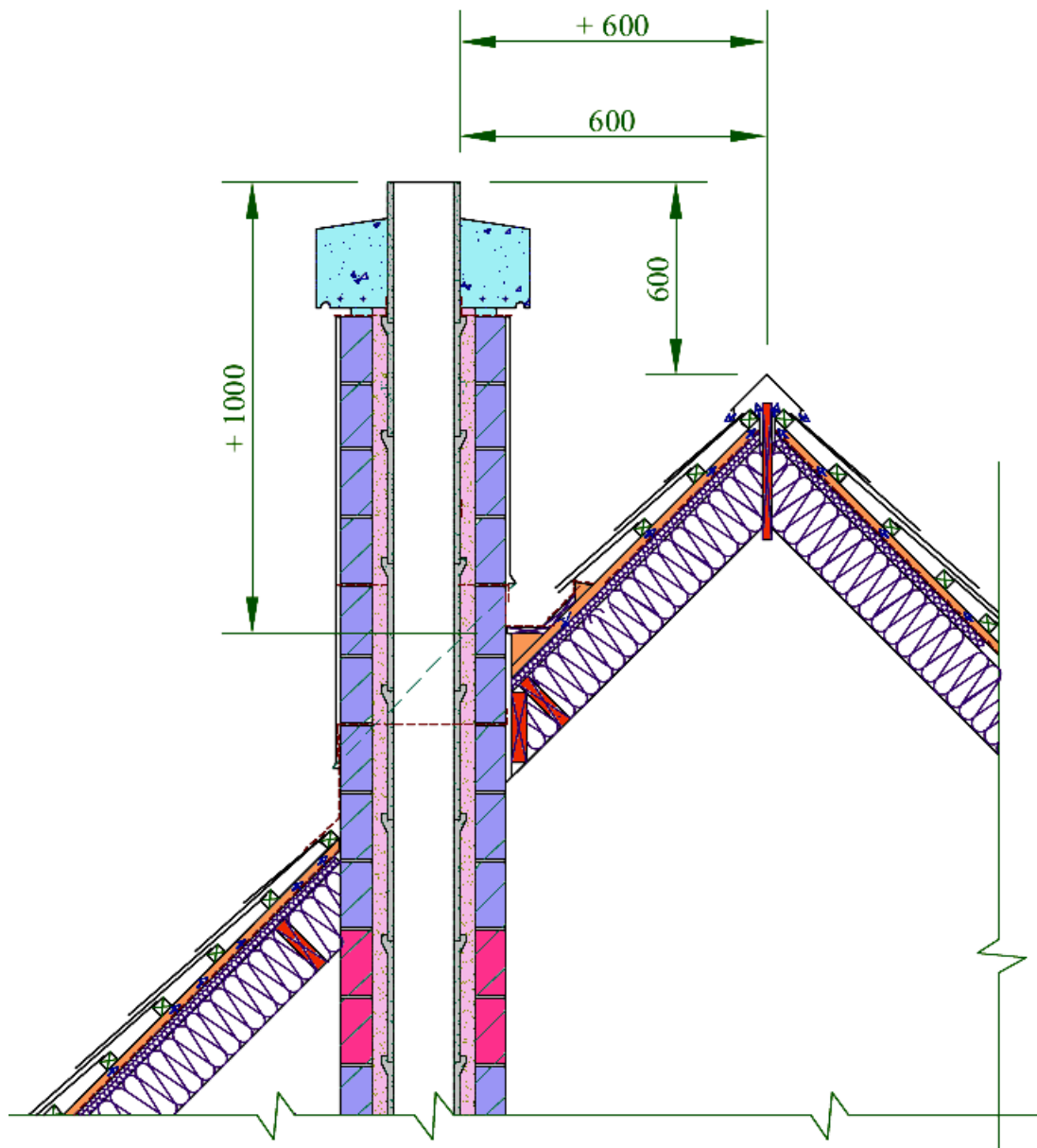
**Ceist 7****Chimney stack penetrating pitched slated roof - typical details**

- slates on battens 50 × 40 mm
- counter battens 50 × 40 mm to provide air space
- breather membrane sealed and taped
- hygroscopic insulation layer – wood fibre board insulation or similar for windtightness
- rafters 200 × 40 mm at 400 - 600 mm centres
- insulation between rafters
- plywood to gutter at rear of chimney stack
- trimmer
- fillet piece
- lead tray
- flashings
- counter flashings
- flue liners
- fill to flue liners – vermiculite or lime / sand mix
- low conductivity blockwork
- cowl (sketch) to help prevent downdraught

***Other appropriate detailing accepted***

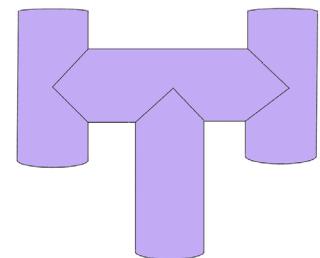



**Ceist 8**

- (a) **Two** advantages and **two** disadvantages of refurbishing the storeroom for use as a home office

**Advantages** – such as:

- refurbishment usually costs less than new build
- a stone building is refurbished not demolished, maintaining the architectural heritage of the locality
- a value system is maintained – reuse, upcycle but do not demolish
- home office reduces need for daily commute to outside office, saving travel time, saving energy -less energy required to travel – helping save the environment through less CO<sub>2</sub>
- sustainability principle of reduce and reuse informing the decision to refurbish
- less materials required in refurbishment, foundations, walls, roofing materials already there
- refurbishment as an exemplar of best practice, showing that an old building can be restored for another use
- a building links to heritage of the area
- the existing garden not damaged with large machinery to dig foundations etc.
- existing planting enhancing the natural setting of the home office - an oasis of calm and delight
- separation of office and home – office for work, home for family activities

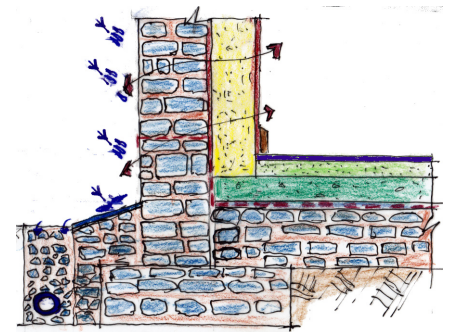
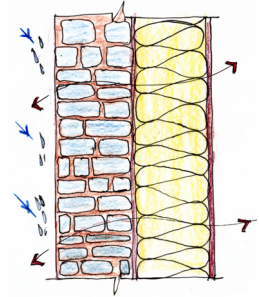
**Disadvantages** – such as:

- building may be quite derelict, refurbishment may not be advisable or achievable
- slow, costly work to maintain the character and appearance of the existing storeroom
- difficult to upgrade to modern office standards
- rising damp can be a challenge in old stone walls
- cannot be externally insulated because of existing stone finish externally
- internal insulation needs to be carefully applied to avoid condensation, dew point and dampness, making the house potentially unhealthy
- location of work very close to house, potentially making it difficult to separate daily work from home activities

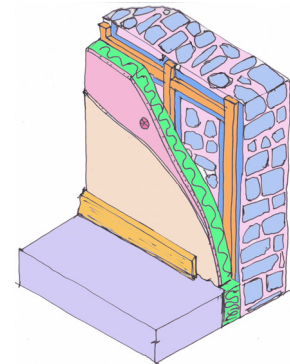

- (b) **Upgrading the random rubble stone walls, 450 mm thick, unrendered**

**Preferable - breathable structure: such as**

- a breathable structure is preferred which allows the gradual movement of moisture from the inside, through the building fabric of the walls
- allows moisture exchange readily between the indoor and outdoor environment, moisture is not trapped within the wall structure

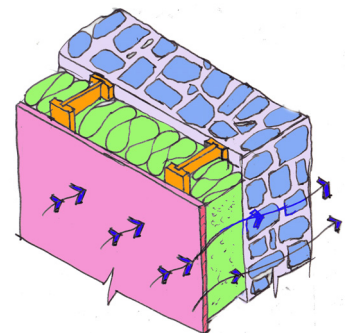

- breathable wall prevents surface and interstitial condensation occurring - as water vapour is not trapped but is gradually released
- ideally maintain the wall as a breathing structure – few barriers as in original
- insulation materials have to be carefully selected - natural insulation materials allow breathability, such as lime, hemp, cork, wood fibreboard, sheep's wool, cotton, flax, earth-based mortars, renders, plasters and limewashes
- natural insulation materials are made from renewable or recyclable natural products, they allow the building to breathe and have excellent hygroscopic properties
- hygroscopic materials absorb the moisture from the air when the humidity is high and release it when the air is dry
- hygroscopic properties of the insulation will allow water vapour to move through the structure
- adding vapour barriers and materials that are highly resistant to the passage of water vapour are generally not appropriate for older stone buildings
- rule of thumb – all layers should become progressively more permeable from the interior to the exterior
- tanking may be required to prevent rising damp - depends on the design of the original wall.

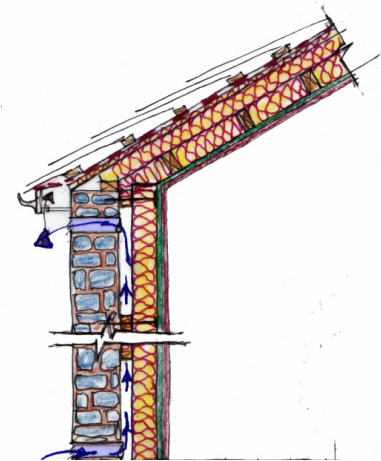
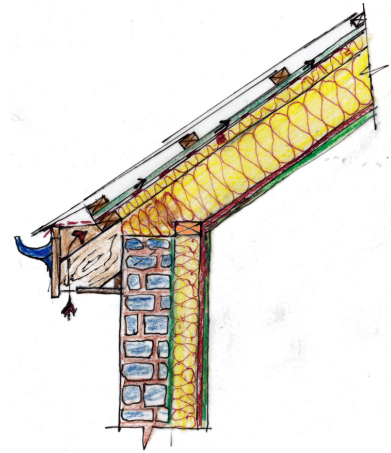

#### Suitable insulation materials include:

- hemp, hemp-lime composites, mineral wool, wood fibre, lime renders

#### Alternative method - non breathable structure

- rigid insulation, mechanically fixed to wall with ventilated cavity - vapour barrier, gypsum slab and gypsum skim
- use of impermeable insulation materials generally requires ventilation - see sketch

#### Re pointing of historic stone work:

- re-pointing of historic stonework is a specialised task
- raking out of the old deteriorated lime mortar must be undertaken with great care and powered angle grinders or concrete saws should not be used
- best practice recommends the use of hand tools
- joints in general should be raked out to a depth twice the face width (sketch)
- before repointing, all joints should be thoroughly brushed out to remove any loose particles - working from the top down
- prior to repointing, the stone wall should be dampened using a fine spray – do not saturate the stone
- use a flat steel jointing bar to apply the lime mortar pointing
- deep pointing will require filling in two stages as the lime mortar needs air to harden
- when the lime mortar hardens, a course bristled brush is used to beat it. This provides a coarse textured mortar with some of the aggregates visible (sketch)
- freshly pointed lime mortar requires protection from the weather for a considerable time period as lime hardens and sets slowly
- hessian matting is frequently used to protect lime from sun, wind, rain and frost

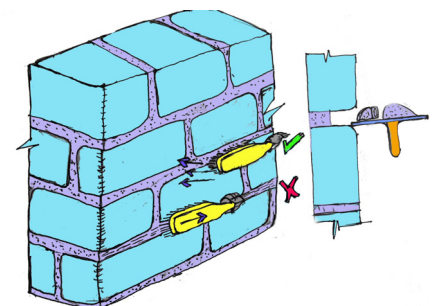

- insulation, straw or hay is also used under the hessian but allowing air circulation to facilitate carbonation occurring.

### Applying lime plaster work to stone - in three coats

- brush down the stone wall to get rid of any dust or loose particles
- all loose lime mortar beds to the stone work should be raked out and repointed prior to rendering
- the stone wall should be dampened down prior to applying lime render
- any hollow spots in the wall should be filled out with lime render mixed with animal hair
- later (2 - 3 days) the scratch coat made up of a weak natural hydraulic lime render (NHL) plus animal hair is applied and left rough textured for better adhesion of following coats
- keep from drying out too quickly – lightly spray with water (mist only) if required
- lay the second or float coat of lime render plus animal hair over the scratch coat
- again texture this float coat
- lay the third and finish coat of lime render using a mix of lime putty and sand.

### Upgrading stone flags on earthen floor

- doing more with less for longer, so try and conserve and reuse the flags if they are in reasonably good condition
- photograph or sketch the floor showing the position of the existing slabs
- number the flags on sketch and as each flag is lifted, number the flags to match photo/sketch
- store the flags securely
- remove earth and replace with compacted hardcore, sand blinding and radon barrier
- for eco-renovation and insulation use a hemp-based slab consisting of hemp/sand/lime subfloor, min 200 mm thick
- fine screed of limecrete on which slabs are laid
- alternatively, concrete subfloor on radon barrier, on sand blinding on compacted hardcore
- sand/cement fine screed on which flags are laid
- flags sealed with proprietary sealant and pointed with proprietary grout or with lime/sand grout
- floor sealed with proprietary sealant.

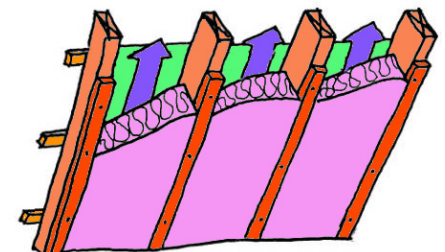
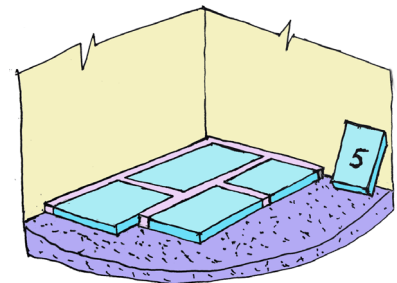

### Upgrading traditional cut roof of natural slate

- good practice - doing more, with less for longer
- all roof structure must be thoroughly vented, otherwise condensation will cause the decay of the roof members, especially if full-fill insulation is used between rafters
- remove natural slates, number and store securely
- examine rafters for decay or wet rot
- good conservation practice - only replace the parts affected by decay/ rot to minimises waste
- cut off ends of rafters affected by wet rot and fix preservative treated softwood timbers to the remaining sound timber on the end of each original rafter
- remove any existing rafters, ceiling joists, fascia and soffit timbers affected by decay or wet rot
- replace with new preservative-treated softwood timbers consistent with the original section

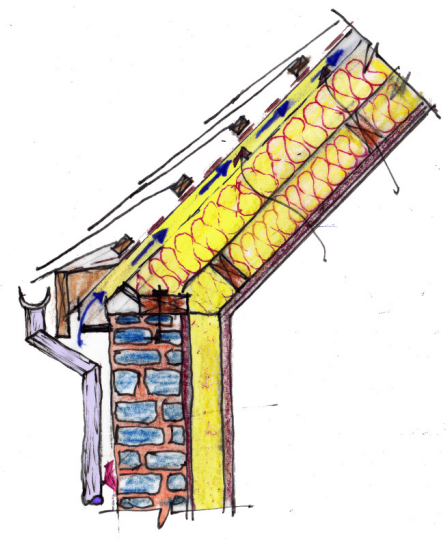

- fit vapour diffuse membrane to replace bitumenous felt – bitumenous felt causes condensation and decay of roof members and should be replaced
- fit optional windtight layer – such as woodfibre, OSB or smartply
- replace slating battens and fix counter battens to ensure ventilation– retaining the original gauge
- all replacement slates secured using clout nails
- source natural slates identical to those on the roof from a derelict building or from an architectural salvage company
- to maintain integrity of main elevation, take slates from rear and place on front
- cut off any section of the fascia and soffit also affected by wet rot and replace with preservative treated timbers having the same moulding as the original timbers
- prime, undercoat and gloss fascia & soffit
- replace damaged cast iron rainwater gutters and downpipes with identical.

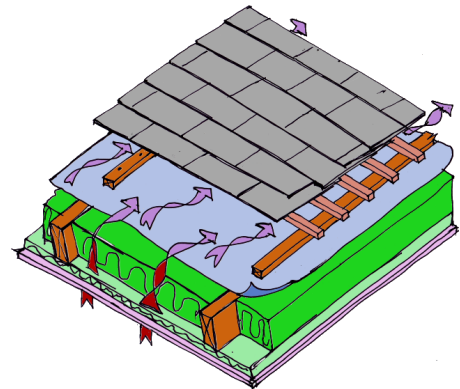

Some references on retrofitting with internal insulation  
<http://www.historic-scotland.gov.uk/technicalpaper15.pdf>

Breaking the Mould: Joe Little Architects

Building Life Consultancy: Joe Little

Residential retrofit 20 case studies: Marion Baeli – RIBA Publishing – ISBN: 978 1 85946 5011

*Irish Stone Walls: Patrick McAfee: 2011: The O'Brien Press, Dublin, ISBN: 978-1-84717-234-1*

*Lime Works: Using lime in traditional & new buildings: Patrick McAfee: 2009 - The Building Limes Forum of Ireland & Associated Editions*

*Stone, Brick and Mortar: Historical Use, Decay and Conservation of Building Materials in Ireland:*

*Sara Pavia and Jason Bolton: 2000 - Wordwell Ltd. ISBN 10: 1869857321*

**Ceist 9. (a)** Typical use in a domestic dwelling:

- ring circuit
- radial circuit.

#### Ring circuit

- the ring circuit is used typically for adjacent rooms in the house
- the ring circuit should not be used in a kitchen
- the number of sockets in a ring circuit is unlimited if the area served is not greater than 100 square metres
- the circuit must have the capacity to carry 0.67 times the rated current of the protective device on the circuit
- cable of 2.5 mm<sup>2</sup> three-core is normally used with a current carrying capacity of 23A
- the calculated maximum current allowable is thus  $23/0.67 = 34.33\text{Amps}$
- the minimum current carrying capacity required is  $32 \times 0.67 = 21.44\text{Amps}$
- the ring circuit is protected by an MCB with a rating of 32A
- the length of copper cable required is kept to a minimum.



#### Radial circuit

- the radial circuit is typically used in a kitchen
- the radial circuit has a maximum of ten sockets per circuit
- the radial circuit should not supply more than two rooms
- a kitchen should be supplied by at least two radial circuits
- the radial circuit should be protected by an MCB rated at 20Amps when 2.5mm<sup>2</sup> cable is used.

**(b) Wiring diagram for two lights controlled by a single switch –**

Loop-in method of wiring the lights

- switch at A
- lamp holders at B
- fuse/MCB/RCB at C
- Earth at E
- 1.5mm<sup>2</sup> PVC/PVC single-core cable for positive and neutral conductors
- brown insulation used for switch feed (+ve) and switch wire and all live conductors
- blue insulation used for all neutral conductors
- lamp holders are connected by circular 0.5 mm<sup>2</sup> heat-resistant flex
- earth wire (protective conductor) is sleeved in Green/Yellow PVC

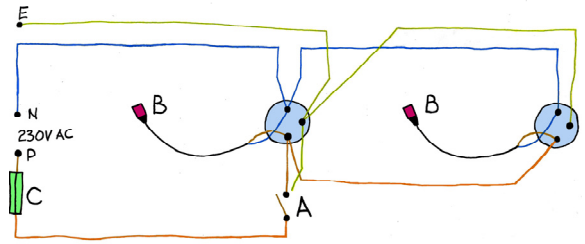

Three Plate Ceiling Rose - wiring the lights – as shown

**Safety features**

- a protective conductor (earth) is provided to both lighting points and the control switch
- correct sizing of electrical cables
- the circuit is protected by a fuse/switch and MCB and RCD
- the control switch interrupts the phase conductor - live
- all circuits to be earthed
- isolation switches to appliances with high current demand – e.g. cooker, electric showers, wall heaters etc.

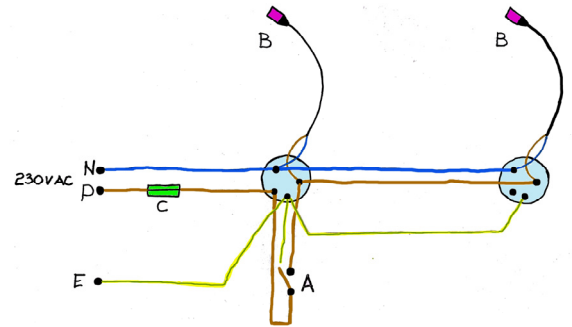
**Electrical Distribution Unit**

A: Main Switch

B: Residual Current Devices - RCDs

C: Miniature Circuit Breakers - MCBs

**(c) Two features in the design of a lighting system to ensure the economical use of electricity**

**Economical use of electricity** – such as –

- separate lighting circuits and lights used only as required
- task lighting - specifically for work/study stations, used only as required
- ambient lighting - general mood lighting in a room
- motion and/or heat sensors fitted to ensure lights are off in uninhabited rooms
- app for switching lights on/off remotely, no wastage
- flexible lighting so lights can be moved about as required, both floor and ceiling
- use the most efficient, low-energy bulbs, normally LED lights
- incandescent bulbs emit 98% of the electricity consumed as heat and are now superseded
- LED lights typically emit 80 to 120 lumens per watt while CFLS emit in the region of 55 lumens per watt - for comparison, incandescent bulbs which were used in the past emitted only 14.3 lumens per watt while the figure for halogen bulbs is 24.6 lumens per watt
- use smart metering to give feedback to occupants encouraging economy by switching off lights when not in use
- use LED desk lamps or reading lamps for tasks when full-room lighting is not required
- use motion sensors to switch off lights in unoccupied rooms
- use automatic light sensors to turn lights on/off as required when the room is unoccupied
- avoid the use of artificial light where possible by maximising natural lighting, roof lights etc.
- avoid obstructions and shading of windows
- provide reflective, light-coloured surfaces on walls, floors and ceilings to reflect available natural light.

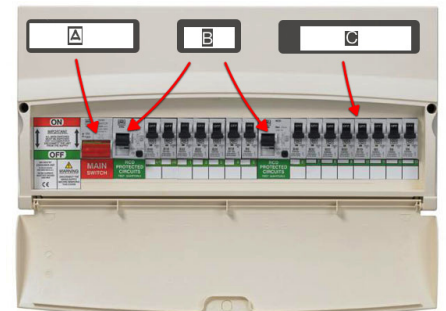

**Ceist 10 (a)****Foundations:**

- passive foundation to achieve U-value of between 0.10 - 0.15 W/m<sup>2</sup> K
- no thermal bridges
- very well insulated to minimise heat loss
- high compressive strength insulation used
- traditional strip foundation with autoclaved aerated concrete blockwork to prevent heat loss
- other approved systems that meet passive standards

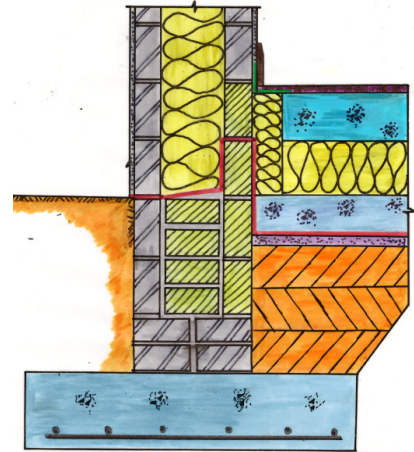
**Ground floor**

- thermal mass - increased thickness of screed and tile finish will improve the capacity of the building to absorb and retain heat
- high levels of insulation
- no thermal bridges
- airtightness
- traditional system is acceptable provided it meets passive standard and incorporates an appropriate heat store
- any other approved system that meets passive standards and incorporates a heat store

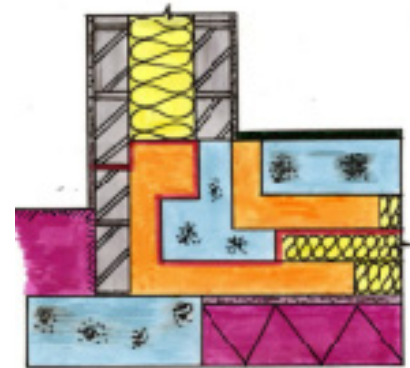
**Walls**

- passive wall to achieve u-value of between 0.10 - 0.15 w/m<sup>2</sup> K
- high level of insulation
- no thermal bridges
- airtightness
- block inner leaf with internal plaster finish will improve thermal mass of the building
- in the case of timber frame passive houses consideration must be given to alternative methods of maximising heat storage such as Trombe wall, high mass floor screeds, internal block walls

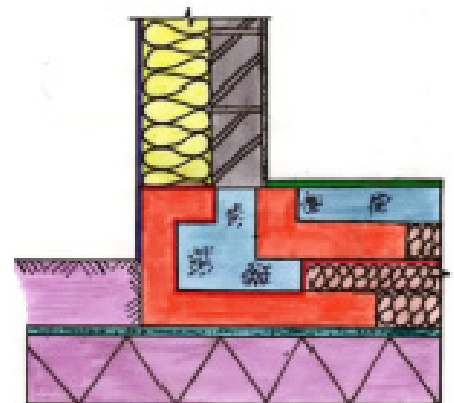
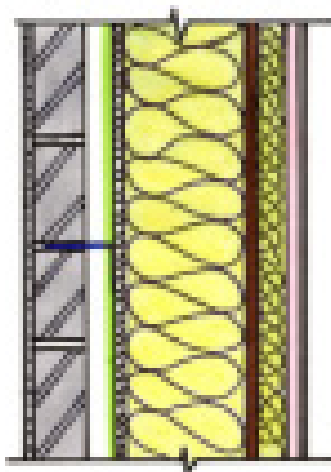
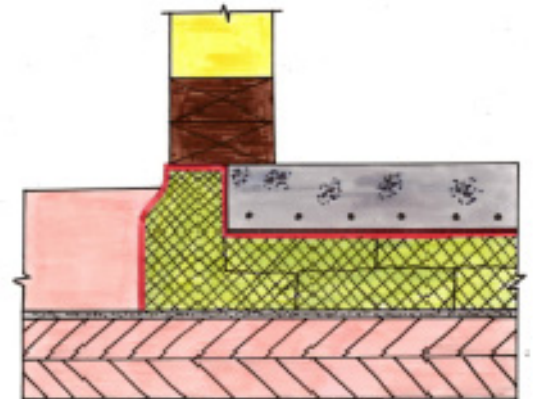

**(b) Reasons why Passive House may overheat – such as**

- passive standard – overheating occurs if internal temperature greater than 25° for 36 days (10%) days annually
- inadequate or no over-shading of windows – no roof overhang, balcony or brise-soleil
- insufficient ventilation – natural or mechanical
- insufficient thermal mass - not appropriate to house size
- poor design detailing, long unvented corridors, small isolated rooms, poor placement of windows
- large amounts of south facing glazing resulting in too much solar heat gain
- inadequate natural shading
- in addition to solar heat gain, heat produced inside the house, lighting, appliances, hot water production and cooking all add to overheating.

**Two design features that reduce the possibility of overheating****Extended roof overhang**

- an overhang / extended eaves / to reduce the amount of solar heat gain in summertime
- the angle of the sun is higher during the summer than it is during the winter. By using a correctly designed overhang, the amount of solar heat gained from the summer sun is reduced. due to the lower angle of the winter sun, winter solar heat gain will not be affected
- ensure MHRV unit has summer bypass setting
- the maximum angle of the summer sun can be calculated by using the following formula  
 $90^\circ - \text{latitude} + 23.5^\circ = \text{maximum sun angle}$
- the minimum angle of the winter sun can be calculated by using the following formula  
 $90^\circ - \text{latitude} - 23.5^\circ = \text{minimum sun angle}$
- designed to allow purging of overheated air – through and through ventilation with openable windows at both ends of building to allow through draught and cooling
- using the above information an appropriate overhang can be designed

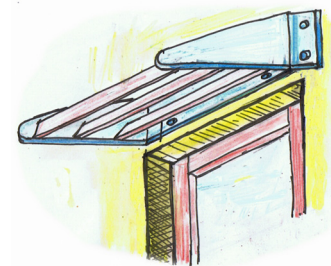
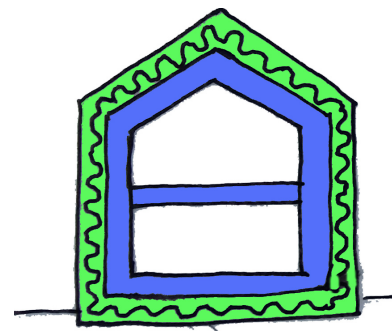
**Brise Soleil**

- this works on the same principle as the overhang and is used to reduce the amount of summer sun entering a building
- adjustable *brise soleil* can be adjusted to suit the weather conditions at a particular time
- external roller blinds, awnings and sliding screens are the most common types

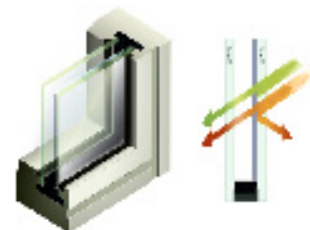
**Thermal mass**

- Include thermal mass in design, external insulation with concrete walls and floors to absorb heat and release slowly

**Dynamic Glass**

- standard float glass with an electrochromic coating applied on one of the surfaces
- automatically adjusts its tint in response to environmental conditions
- eliminates the need for blinds or shades
- allows visible light to enter the building while filtering out infra-red and ultraviolet light

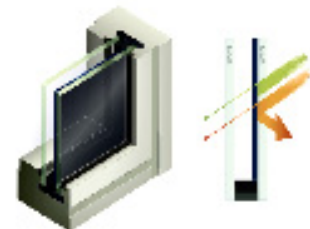

- can be used in any situation where excessive solar heat gain is likely to be an issue, for example south facing glazing
- dynamic glass allows control over the amount of infra-red as well as solar gain that enters the building
- occupants can manually control tint of glass by apps on smart phones / tablets or by wall switches
- achieves a reduction of up to 20% in energy consumption
- provides an important advancement in sustainable design

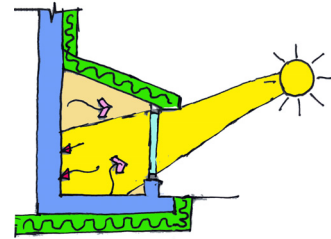

### (c) Passive house standard a planning requirement

#### Advantages of passive house construction:

- low energy consumption - a typical passive house uses 75% less energy than a similar house built to building regulations standards,
- comfort - passive house construction provides a consistent level of comfort (a constant comfortable temperature of 20°C is maintained all year round),
- economical - a typical passive house significantly cheaper to run than a similar house built to building regulations standards - 75% energy reduction,
- reduced environmental impact - lower energy consumption means that passive houses have a much smaller carbon footprint than houses built to building regulations standards - reduced CO<sub>2</sub> emissions

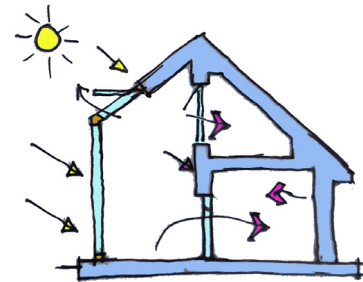

#### Disadvantages of passive house construction:

- workmanship - a very high level of workmanship is required on site - every member of the construction team must understand what is required to achieve passive house standard and ensure that their work is of the highest possible standard
- training - tradespeople and designers need to be trained to ensure they are competent to achieve passive house standards
- materials - quality materials, expensive
- capital cost - expensive
- longer contract time required to complete passive house
- a private standard, must pay to have house certified as *PassivHaus*.

#### Any other relevant points

#### Additional information

When designing a passive house the heat load is calculated on two sample days:

- a mild overcast day (high temperature, low solar gain),
- a cold clear day (low temperature, high solar gain).

Whichever calculation produces the greater heat load is used when designing the house. Doing this ensures the house will perform adequately in a 'worst case scenario'. It is usually the mild, overcast day that creates a higher heat load, because on a cold clear day the benefit of solar gain outweighs the drawback of a cold temperature.

**Note:** the building regulations also have a requirement for primary energy demand but these are not the same - in the passive house standard everything is included (e.g. space heating, water heating, ventilation, lighting, appliances such as the dishwasher and the television) whereas in the building regulations only space heating, water heating, ventilation and lighting are included.



**Ceist 10.**

*One of the greatest challenges and opportunities for sustainable development is the reuse of our existing buildings for multiple uses. This gives vitality, density, security, utility and beauty to our countryside, villages, towns and cities.*

**Repairing and Reusing an 18th Century House** – Report by Robin Mandal Architects.  
Issue 283 - The Journal of the Royal Institute of the Architects of Ireland, 2015.

Discussion of the above statement in detail – such as:

- the present-day uses of buildings will, in many instances, be very different to the functions for which they were first designed
- the best-practice guidelines for re-use should have this in mind and encourage uses that meet a need today, even if this means that considerable remodelling is needed to make the building suitable for re-use
- guidelines should aim to ensure that such sensitive modifications are allowed and that these do not provide an unnecessary impediment to reuse
- guidelines should be respectful of the original structure, aesthetic and beauty of the original building
- if the requirements insist on over stringent restoration of the original building, costs may become prohibitive and the suitability of the building for re-use may be diminished
- if the re-use of the building is not made achievable then it is likely to degrade, fall into disrepair and eventually may be demolished to make way for a new building and the heritage is lost forever
- best-practice guidelines should take account of the immediate surroundings of the building to be refurbished
- in some cases the interior of the building may have been so degraded that refurbishment is impossible or the cost may be prohibitive. Then the focus should be on the exterior of the building, the interior being freely reimagined to suit the priorities imposed by the new use of the building
- best-practice guidelines should encourage the drawing up of realistic area plans to give a focus to the reimagining and refurbishment
- an inventory of buildings in both rural and urban areas suitable for retrofitting and reuse – bringing back charm of urban living and breathing life into derelict buildings in the countryside and in towns
- modest scale of existing buildings often more appropriate for repair and reuse – built in more frugal times but now more appropriate for a sustainability age than newer buildings of large scale and wasteful of resources
- architects can creatively reimagine new uses and new layouts by creative yet realistic plans
- the upgrading of derelict areas can bring new tenants, new businesses and a new vitality to such areas
- restoring mixed use buildings for young and elderly, together with provision for the arts, artists' studios, art galleries, cafes etc. can bring back life and energy to a derelict area
- as a general rule, the original building should be legible and the new alterations should not mask or distort the integrity of the original structure
- modifications often require some intrusion, such as fitting a lift, widening doors, toilets for universal design, to make the building suitable for universal access
- reuse and upgrading of existing buildings can lead to a new vitality in the areas upgraded. examples of good practice, such as the refurbishment of the Temple Bar area in Dublin, can offer a pattern as to how such approaches could be successful
- building on past experience should lead to the avoidance of mistakes and should lead to a new appreciation of the importance of tradition, having existing buildings envisioned in new ways, light-filled, lean, beautiful, delightful and a joy to behold

---

**Three** best practice guidelines that would promote the refurbishment and reuse of existing buildings in Ireland – such as:

- the refurbishment should be as true as practicable to the original layout, materials and construction processes used in the initial construction of the building
- successful refurbishments should be promoted as exemplars of best practice and should encourage others to follow example – dissemination of skills learned in restoration work
- conservation grants, supports for individuals and organisations undertaking refurbishment
- guidelines for best practice should be widely disseminated to ensure broad design-based expertise
- conservation architects/designers as part of the design team to ensure best advice is available
- any design or construction defects in the original building should be identified and remedial works to correct these defects should be considered
- subsequent works carried out in the course of the life of the building should be identified and their reversal or incorporation into the refurbishment considered
- the new use to which it is proposed to put the building should be specified, clearly stating those elements that are essential if the building is to successfully meet the new requirements
- following due consideration, all works identified as essential to the successful re-use of the building should be incorporated into the refurbishment plan
- priority should be given to the successful reassignment of the building to a new use or uses. Successful retention of the building into the future is dependent on the extent to which the building meets the requirements of its newly acquired function
- where appropriate, public monies and resources should be used to encourage thoughtful refurbishment
- the whole community benefits when the amenity value of a street or area is enhanced by refurbishment and reuse of buildings.

*Any other relevant, cogent, well-argued points.*



**Coimisiún na Scrúduithe Stáit**  
*State Examinations Commission*

# *Staidéar Foirgníochta*

## *Teoiric – Ardleibhéal*

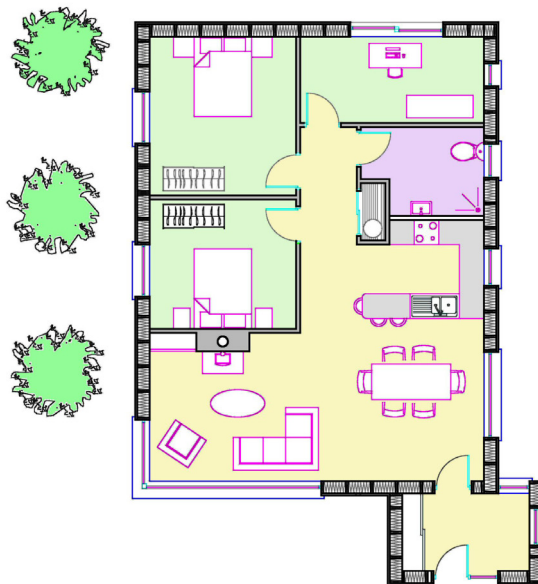
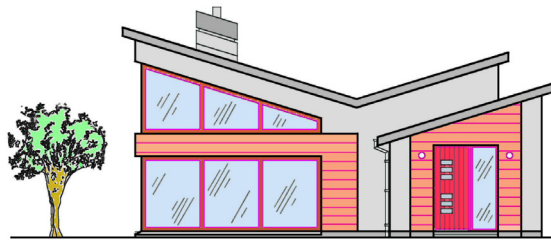

# *Construction Studies*

## *Theory – Higher Level*

### *Marking Scheme*

## CEIST 1

PERFORMANCE CRITERIA	MAXIMUM MARK
<b><i>Timber flat roof, external walls and window</i></b> <span style="float: right;"><b><i>(11 × 4 marks)</i></b></span>	
<b><i>(Drawing 3, Annotation 1)</i></b>	
<ul style="list-style-type: none"> <li>• Lead flashing</li> <li>• Bituminous felt</li> <li>• Eaves batten/drip</li> <li>• Plywood decking</li> <li>• Counter battens/ventilation</li> <li>• Tilting fillet</li> <li>• Breather membrane</li> <li>• Joist &amp; roof insulation</li> <li>• Wallplate</li> <li>• Vapour control layer</li> <li>• Hanger to main wall/metal hangers</li> <li>• Insulated plasterboard</li> <li>• Fascia / Soffit / Gutter <i>(any 2)</i></li> <li>• Cavity wall &amp; wall ties</li> <li>• Cavity closer</li> <li>• Wall insulation</li> <li>• Internal and external renders</li> <li>• Stepped DPC in cavity</li> <li>• Lintels</li> <li>• Window frame - thermally broken <i>(2 marks without thermal break)</i></li> <li>• Triple-glazed unit</li> <li>• Airtightness tapes to ceiling and windows</li> </ul>	<p><b>4</b></p> <p><b>4</b></p> <p><b>4</b></p> <p><b>4</b></p> <p><b>4</b></p> <p><b>4</b></p> <p><b>4</b></p> <p><b>4</b></p> <p><b>4</b></p> <p><b>4</b></p> <p><b>4</b></p> <p><b>4</b></p> <p><b>4</b></p> <p><b>4</b></p> <p><b>4</b></p> <p><b>4</b></p> <p><b>4</b></p> <p><b>4</b></p> <p><b>4</b></p> <p><b>4</b></p>
<b>Four typical dimensions</b>	<b>4</b>
Scale    4 marks	<b>8</b>
Drafting    4 marks	<i>(Excellent, Good, Fair)</i>
	4    3    2
Design detail to prevent the ingress of water	<b>4</b>
<b>TOTAL</b>	<b>60</b>

## CEIST 2

PERFORMANCE CRITERIA	MAXIMUM MARK
<b>(a) Discuss development of positive safety culture among workers (2 × 6 marks)</b>	
<p><b>Safety training</b> <i>2 marks for point, 4 marks for discussion</i></p>	<b>6</b>
<p><b>Collective responsibility</b> <i>2 marks for point, 4 marks for discussion</i></p>	<b>6</b>
<b>(b) Discuss appropriate use of ladder (2 × 6 marks)</b>	
<p><b>Level of risk</b> <i>2 marks for point, 4 marks for discussion</i></p>	<b>6</b>
<p><b>Duration of task</b> <i>2 marks for point, 4 marks for discussion</i></p>	<b>6</b>
<b>(c) Discuss guidelines for safe use of ladder to scaffold platform (6 × 6 marks)</b>	
<p><b>Guideline 1</b></p>	<b>6</b>
Notes	
Sketches	<b>6</b>
<p><b>Guideline 2</b></p>	<b>6</b>
Notes	
Sketches	<b>6</b>
<p><b>Guideline 3</b></p>	<b>6</b>
Notes	
Sketches	<b>6</b>
<b>TOTAL</b>	<b>60</b>

## CEIST 3

PERFORMANCE CRITERIA	MAXIMUM MARK
<b>(a) Redesign - two features:</b> <i>(note 10 marks, sketch 10 marks)</i>	
<p><b>Design feature external envelope</b></p> <p>Notes</p>	<b>10</b>
<p>Sketches</p>	<b>10</b>
<p><b>Design feature internal layout</b></p> <p>Notes</p>	<b>10</b>
<p>Sketches</p>	<b>10</b>
<b>(b) Detailed discussion of reasons for redesign of building</b> <i>(2 × 10 marks)</i>	
<p><b>Redesign 1 -</b></p> <p>Discussion</p>	<b>10</b>
<p><b>Redesign 2 -</b></p> <p>Discussion</p>	<b>10</b>
<b>TOTAL</b>	<b>60</b>

## CEIST 4

PERFORMANCE CRITERIA	MAXIMUM MARK
<b>(a) Discussion on suitability of site - any three reasons</b>	<b>(3 × 6 marks)</b>
Reason 1	<b>6</b>
Reason 2	<b>6</b>
Reason 3	<b>6</b>
<b>(b) Sketch, location, orientation, entrance and access, justification</b>	<b>(5 × 6 marks)</b>
Sketches	<b>6</b>
Location and orientation of house on site	<b>6</b>
Entrance gateway and access road	<b>6</b>
Justification 1	<b>6</b>
Justification 2	<b>6</b>
<b>(c) One-off houses in rural landscape</b>	<b>(4 × 3 marks)</b>
Advantage 1	<b>3</b>
Advantage 2	<b>3</b>
Disadvantage 1	<b>3</b>
Disadvantage 2	<b>3</b>
<b>TOTAL</b>	<b>60</b>

## CEIST 5

PERFORMANCE CRITERIA	MAXIMUM MARK
<b><i>(a) U-value of external wall</i></b> <span style="float: right;"><b><i>(10 × 3 marks)</i></b></span>	
External plaster	<b>3</b>
External block	<b>3</b>
OSB Racking Board	<b>3</b>
Mineral Wool Insulation	<b>3</b>
Plasterboard	<b>3</b>
Cavity	<b>3</b>
External surface resistance	<b>3</b>
Internal surface resistance	<b>3</b>
Total resistance	<b>3</b>
U-value of external wall <i>(1 mark for formula)</i>	<b>3</b>
<b><i>(b) Annual heat loss through specified wall – Wall A</i></b> <span style="float: right;"><b><i>(5 × 3 marks)</i></b></span>	
Heat loss formula and calculation	<b>3</b>
Heating duration for one year	<b>3</b>
k/Joules calculation for one year	<b>3</b>
Litres of oil for one year	<b>3</b>
Annual cost of heat loss	<b>3</b>
<b><i>(c) Upgrade to Passive House: U - value of 0.15 W/m<sup>2</sup> °C - Wall B</i></b> <span style="float: right;"><b><i>(5 × 3 marks)</i></b></span>	
Resistance for U-value of 0.15 W/m <sup>2</sup> °C	<b>3</b>
Existing resistance from part (a)	<b>3</b>
Difference in resistances (required resistance)	<b>3</b>
Application of formula $R = T/k$	<b>3</b>
Required thickness of insulation	<b>3</b>
<b>TOTAL</b>	<b>60</b>



## CEIST 6

PERFORMANCE CRITERIA	MAXIMUM MARK
<b><i>(a) Low environmental impact design - three design features</i></b>	<b><i>(6 × 5 marks)</i></b>
<b>Design feature 1</b>	<b>5</b>
Notes	
Sketches	<b>5</b>
<b>Design feature 2</b>	<b>5</b>
Notes	
Sketches	<b>5</b>
<b>Design feature 3</b>	<b>5</b>
Notes	
Sketches	<b>5</b>
<b><i>(b) One means of generating on-site renewable energy</i></b>	<b><i>(2 × 10 marks)</i></b>
Notes	<b>10</b>
Sketches	<b>10</b>
<b><i>(c) Advantages of generating renewable energy on-site</i></b>	<b><i>(2 × 5 marks)</i></b>
On-site generation - advantage 1	<b>5</b>
On-site generation - advantage 2	<b>5</b>
<b>TOTAL</b>	<b>60</b>

## CEIST 7

PERFORMANCE CRITERIA	MAXIMUM MARK
<b>(a) Vertical section through chimney stack and roof structure (11 × 4 marks)</b>	
• Blockwork	4
• Render	4
• Flue Liners	4
• Fill	4
• Chimney capping	4
• Cover flashing × 2	4
• Under flashing (apron)	4
• Flashing to rear gutter	4
• Apron or tray	4
• Rafter	4
• Fillet piece	4
• Breather membrane	4
• Battens / Counter battens	4
• Trimmer	4
• Slates	4
Scale	4
Drafting	4
(Excellent, good, fair) (4, 3, 2)	4
<b>(b) Best practice design considerations to prevent a downdraught (8 marks)</b>	
Design detail 1 -	2
Design detail 2 -	2
Typical dimensions (2 × 2 marks)	4
<b>TOTAL</b>	<b>60</b>

## CEIST 8

PERFORMANCE CRITERIA	MAXIMUM MARK
<b><i>(a) Refurbishment of storeroom to home office</i></b> <span style="float: right;"><b><i>(4 × 5 marks)</i></b></span>	
Advantage 1	<b>5</b>
Advantage 2	<b>5</b>
Disadvantage 1	<b>5</b>
Disadvantage 2	<b>5</b>
<b><i>(b) Design detailing to upgrade storeroom - 2 areas (4 × 8 marks), (2 × 4 marks)</i></b>	
<b>Upgrading walls</b>	<b>8</b>
Notes	<b>8</b>
Sketches	
<b>Upgrading roof</b>	<b>8</b>
Notes	<b>8</b>
Sketches	
<b>Upgrading floor</b>	
Notes	
Sketches	
Justification for design choices - area 1	<b>4</b>
Justification for design choices - area 2	<b>4</b>
<b>TOTAL</b>	<b>60</b>

## CEIST 9

PERFORMANCE CRITERIA	MAXIMUM MARK
<b>(a) Location for circuits</b>	<b>(2 × 4 marks)</b>
Ring circuit – typical location in house	<b>4</b>
Radial circuit - typical location in house	<b>4</b>
<b>(b) Typical electrical circuit design</b>	<b>(1 × 12 marks) and (4 × 6 marks)</b>
Annotated sketch for switch and two lights	<b>12</b>
Typical sizes of cables (3 × 2 marks)	<b>6</b>
Colour coding of cables (3 × 2 marks)	<b>6</b>
Safety feature 1 in design of circuit	<b>6</b>
Safety feature 2 in design of circuit	<b>6</b>
<b>(c) Features in design of circuit for economical use of electricity</b>	<b>(2 × 8 marks)</b>
Design feature 1 in circuit	<b>8</b>
Design feature 2 in circuit	<b>8</b>
<b>TOTAL</b>	<b>60</b>

## Ceist 10

PERFORMANCE CRITERIA	MAXIMUM MARK
<b>(a) Best practice design detailing - any 2</b>	<b>(4 × 6 marks)</b>
<b>Foundations</b>	
Notes	<b>6</b>
Sketches	<b>6</b>
<b>Ground Floor</b>	<b>6</b>
Notes	<b>6</b>
Sketches	<b>6</b>
<b>Walls</b>	<b>6</b>
Notes	<b>6</b>
Sketches	<b>6</b>
<b>(b) Two reasons why overheating occurs</b>	<b>(2 × 6 marks)</b>
<b>Two design details to reduce the possibility of overheating</b>	<b>(2 × 6 marks)</b>
Reason 1 for overheating	<b>6</b>
Reason 2 for overheating	<b>6</b>
Design detail 1 (note and sketch)	<b>6</b>
Design detail 2 (note and sketch)	<b>6</b>
<b>(c) Passive House standard as planning requirement</b>	<b>(4 × 3 marks)</b>
Advantage 1	<b>3</b>
Advantage 2	<b>3</b>
Disadvantage 1	<b>3</b>
Disadvantage 2	<b>3</b>
<b>TOTAL</b>	<b>60</b>

**CEIST 10 (Alternative)**

<b>PERFORMANCE CRITERIA</b>		
<b><i>Discussion of statement</i></b>		<b><i>(3 × 10 marks)</i></b>
Discussion – point 1	<i>(4 for point, 6 for discussion)</i>	<b>10</b>
Discussion – point 2	<i>(4 for point, 6 for discussion)</i>	<b>10</b>
Discussion – point 3	<i>(4 for point, 6 for discussion)</i>	<b>10</b>
<b><i>Three best practice guidelines</i></b>		<b><i>(3 × 10 marks)</i></b>
Recommendation 1	<i>(4 for point, 6 for discussion)</i>	<b>10</b>
Recommendation 2	<i>(4 for point, 6 for discussion)</i>	<b>10</b>
Recommendation 3	<i>(4 for point, 6 for discussion)</i>	<b>10</b>
<b>TOTAL</b>		<b>60</b>



**Coimisiún na Scrúduithe Stáit**  
*State Examinations Commission*

*Scrúdú na hArdteistiméireachta 2016*  
*Leaving Certificate Examination 2016*

*Scéim Mharcála*  
*Marking Scheme*  
*(150 marc)*

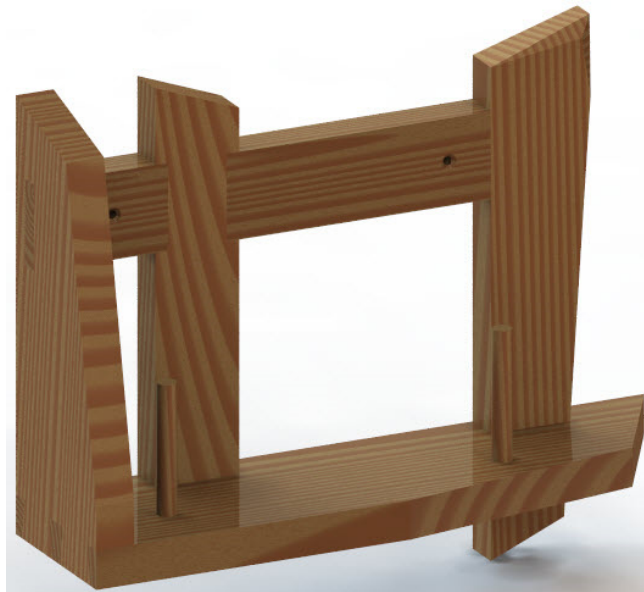

*Staidéar Foirgníochta*  
*Triail Phraiticiúil*

*Construction Studies*  
*Practical Test*

## Construction Studies 2016 Marking Scheme – Practical Test

**Note:**

The artefact is to be hand produced by candidates without the assistance of machinery. However the use of a battery powered screwdriver is allowed.

Where there is evidence of the use of machinery for a particular procedure a penalty applies.

Component is marked out of 50% of the marks available for that procedure.

	<b>(i)</b>	<b>OVERALL ASSEMBLY</b>	<b>MARKS</b>
	1	Overall quality of assembled artefact	<b>9</b>
	2	Dowels located and fitted correctly	<b>4</b>
	3	Design and applied shaping to edges <ul style="list-style-type: none"> <li>• design <span style="float: right;"><i>(3 marks)</i></span></li> <li>• shaping <span style="float: right;"><i>(3 marks)</i></span></li> </ul>	<b>6</b>
	<b>Total</b>		<b>19</b>

	<b>(ii)</b>	<b>MARKING OUT</b>	<b>Marks</b>
	1	Piece A <ul style="list-style-type: none"> <li>• joints – dovetails <span style="float: right;"><i>(2 × 3 marks)</i></span></li> <li style="padding-left: 20px;">- mortice <span style="float: right;"><i>(2 marks)</i></span></li> <li>• slopes <span style="float: right;"><i>(2 × 1 mark)</i></span></li> </ul>	<b>10</b>
	2	Piece B <ul style="list-style-type: none"> <li>• joints - dovetail halving <span style="float: right;"><i>(4 marks)</i></span></li> <li style="padding-left: 20px;">- halving <span style="float: right;"><i>(4 marks)</i></span></li> <li>• slope <span style="float: right;"><i>(1 mark)</i></span></li> </ul>	<b>9</b>
	3	Piece C <ul style="list-style-type: none"> <li>• joints - mortice <span style="float: right;"><i>(2 marks)</i></span></li> <li style="padding-left: 20px;">- trenches <span style="float: right;"><i>(2 × 2 marks)</i></span></li> <li>• slopes and chamfers <span style="float: right;"><i>(5 × 1 mark)</i></span></li> </ul>	<b>11</b>
	4	Piece D <ul style="list-style-type: none"> <li>• joints - bare-faced tenon <span style="float: right;"><i>(2 marks)</i></span></li> <li style="padding-left: 20px;">- trench <span style="float: right;"><i>(2 marks)</i></span></li> <li style="padding-left: 20px;">- tenon <span style="float: right;"><i>(3 marks)</i></span></li> </ul>	<b>7</b>
	5	Piece E <ul style="list-style-type: none"> <li>• joints - dovetail pins <span style="float: right;"><i>(2 × 3 marks)</i></span></li> <li style="padding-left: 20px;">- trenches <span style="float: right;"><i>(2 × 2 marks)</i></span></li> <li>• slopes <span style="float: right;"><i>(2 × 1 mark)</i></span></li> </ul>	<b>12</b>
<b>Total</b>		<b>49</b>	

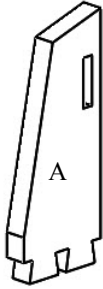

PIECE A	(iii)	PROCESSING	Marks
	1	Dovetails <i>(7 × 1 mark)</i>	7
	2	Mortice <i>(3 marks)</i>	3
	3	Shaping <i>(2 marks)</i>	2
		<b>Total</b>	<b>12</b>

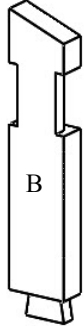
PIECE B	(iv)	PROCESSING	Marks
	1	Trenches <i>(3 × 3 marks)</i>	9
	2	Dovetail <i>(6 marks)</i>	6
	3	Shaping • sloped edge <i>(1 mark)</i>	1
		<b>Total</b>	<b>16</b>

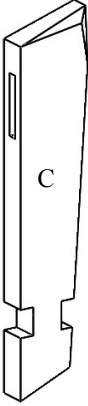
PIECE C	(v)	PROCESSING	Marks
	1	Stopped Mortice <i>(4 marks)</i>	4
	2	Trenches • sawing across the grain • paring trenches <i>(4 × 1 mark)</i> <i>(2 × 2 marks)</i>	8
	3	shaping • sloped edges • chamfers <i>(3 × 1 mark)</i> <i>(2 × 1 mark)</i>	5
		<b>Total</b>	<b>17</b>

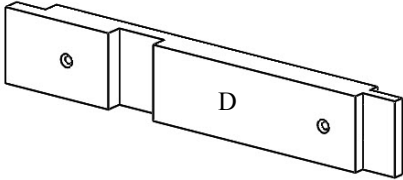
PIECE D	(vi)	PROCESSING	Marks
	1	Bare Faced Tenon <i>(3 marks)</i>	3
	2	Halving <ul style="list-style-type: none"> <li>sawing across the grain <i>(2 × 1 mark)</i></li> <li>paring trench <i>(2 marks)</i></li> </ul>	4
	3	Tenon <ul style="list-style-type: none"> <li>sawing with grain <i>(2 × 2 marks)</i></li> <li>sawing across the grain <i>(2 × 1 mark)</i></li> </ul>	6
	4	Drilling and countersinking holes <i>(2 × 2 marks)</i>	4
		<b>Total</b>	<b>17</b>

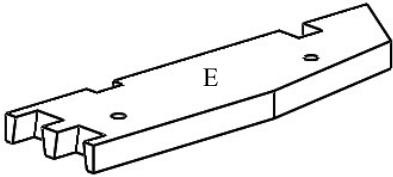
PIECE E	(vii)	PROCESSING	Marks
	1	Dovetail pins <ul style="list-style-type: none"> <li>vertical sawing <i>(4 × 1 mark)</i></li> <li>cutting across grain <i>(2 × 3 marks)</i></li> </ul>	10
	2	Dovetail halving <ul style="list-style-type: none"> <li>sawing across grain <i>(2 × 1 mark)</i></li> <li>paring trench <i>(2 marks)</i></li> </ul>	4
	3	Trench <ul style="list-style-type: none"> <li>sawing across the grain <i>(2 × 1 mark)</i></li> <li>paring trench <i>(2 marks)</i></li> </ul>	4
	3	Shaping sloped ends <i>(2 × 1 mark)</i>	2
		<b>Total</b>	<b>20</b>

**Blank Page**

